

TPS60400EVM-178 for Evaluating TPS6040x Charge Pump Devices

User's Guide

IMPORTANT NOTICE

Texas Instruments and its subsidiaries (TI) reserve the right to make changes to their products or to discontinue any product or service without notice, and advise customers to obtain the latest version of relevant information to verify, before placing orders, that information being relied on is current and complete. All products are sold subject to the terms and conditions of sale supplied at the time of order acknowledgment, including those pertaining to warranty, patent infringement, and limitation of liability.

TI warrants performance of its products to the specifications applicable at the time of sale in accordance with TI's standard warranty. Testing and other quality control techniques are utilized to the extent TI deems necessary to support this warranty. Specific testing of all parameters of each device is not necessarily performed, except those mandated by government requirements.

Customers are responsible for their applications using TI components.

In order to minimize risks associated with the customer's applications, adequate design and operating safeguards must be provided by the customer to minimize inherent or procedural hazards.

TI assumes no liability for applications assistance or customer product design. TI does not warrant or represent that any license, either express or implied, is granted under any patent right, copyright, mask work right, or other intellectual property right of TI covering or relating to any combination, machine, or process in which such products or services might be or are used. TI's publication of information regarding any third party's products or services does not constitute TI's approval, license, warranty or endorsement thereof.

Reproduction of information in TI data books or data sheets is permissible only if reproduction is without alteration and is accompanied by all associated warranties, conditions, limitations and notices. Representation or reproduction of this information with alteration voids all warranties provided for an associated TI product or service, is an unfair and deceptive business practice, and TI is not responsible nor liable for any such use.

Resale of TI's products or services with statements different from or beyond the parameters stated by TI for that product or service voids all express and any implied warranties for the associated TI product or service, is an unfair and deceptive business practice, and TI is not responsible nor liable for any such use.

Also see: [Standard Terms and Conditions of Sale for Semiconductor Products](http://www.ti.com/sc/docs/stdterms.htm). www.ti.com/sc/docs/stdterms.htm

Mailing Address:

Texas Instruments
Post Office Box 655303
Dallas, Texas 75265

EVM IMPORTANT NOTICE

Texas Instruments (TI) provides the enclosed product(s) under the following conditions:

This evaluation kit being sold by TI is intended for use for **ENGINEERING DEVELOPMENT OR EVALUATION PURPOSES ONLY** and is not considered by TI to be fit for commercial use. As such, the goods being provided may not be complete in terms of required design-, marketing-, and/or manufacturing-related protective considerations, including product safety measures typically found in the end product incorporating the goods. As a prototype, this product does not fall within the scope of the European Union directive on electromagnetic compatibility and therefore may not meet the technical requirements of the directive.

Should this evaluation kit not meet the specifications indicated in the EVM User's Guide, the kit may be returned within 30 days from the date of delivery for a full refund. THE FOREGOING WARRANTY IS THE EXCLUSIVE WARRANTY MADE BY SELLER TO BUYER AND IS IN LIEU OF ALL OTHER WARRANTIES, EXPRESSED, IMPLIED, OR STATUTORY, INCLUDING ANY WARRANTY OF MERCHANTABILITY OR FITNESS FOR ANY PARTICULAR PURPOSE.

The user assumes all responsibility and liability for proper and safe handling of the goods. Further, the user indemnifies TI from all claims arising from the handling or use of the goods. Please be aware that the products received may not be regulatory compliant or agency certified (FCC, UL, CE, etc.). Due to the open construction of the product, it is the user's responsibility to take any and all appropriate precautions with regard to electrostatic discharge.

EXCEPT TO THE EXTENT OF THE INDEMNITY SET FORTH ABOVE, NEITHER PARTY SHALL BE LIABLE TO THE OTHER FOR ANY INDIRECT, SPECIAL, INCIDENTAL, OR CONSEQUENTIAL DAMAGES.

TI currently deals with a variety of customers for products, and therefore our arrangement with the user **is not exclusive**.

TI assumes **no liability for applications assistance, customer product design, software performance, or infringement of patents or services described herein**.

Please read the EVM User's Guide and, specifically, the EVM Warnings and Restrictions notice in the EVM User's Guide prior to handling the product. This notice contains important safety information about temperatures and voltages. For further safety concerns, please contact the TI application engineer.

Persons handling the product must have electronics training and observe good laboratory practice standards.

No license is granted under any patent right or other intellectual property right of TI covering or relating to any machine, process, or combination in which such TI products or services might be or are used.

Mailing Address:

Texas Instruments
Post Office Box 655303
Dallas, Texas 75265

EVM WARNINGS AND RESTRICTIONS

It is important to operate this EVM within the specified input and output ranges described in the EVM User's Guide.

Exceeding the specified input range may cause unexpected operation and/or irreversible damage to the EVM. If there are questions concerning the input range, please contact a TI field representative prior to connecting the input power.

Applying loads outside of the specified output range may result in unintended operation and/or possible permanent damage to the EVM. Please consult the EVM User's Guide prior to connecting any load to the EVM output. If there is uncertainty as to the load specification, please contact a TI field representative.

During normal operation, some circuit components may have case temperatures greater than 60°C. The EVM is designed to operate properly with certain components above 60°C as long as the input and output ranges are maintained. These components include but are not limited to linear regulators, switching transistors, pass transistors, and current sense resistors. These types of devices can be identified using the EVM schematic located in the EVM User's Guide. When placing measurement probes near these devices during operation, please be aware that these devices may be very warm to the touch.

Mailing Address:

Texas Instruments
Post Office Box 655303
Dallas, Texas 75265

Read This First

About This Manual

This user's guide describes the TPS60400EVM-178 evaluation module (EVM). The TPS6040x family of devices are unregulated voltage inverters. The family is intended for use with input voltages between 1.8 V and 5 V.

The user's guide contains the EVM schematic with a bill of materials that shows the components used and their manufacturers. The layout and the component placement of the top and bottom sides of the board is shown.

How to Use This Manual

This document contains the following chapters:

- Chapter 1—Introduction
- Chapter 2—Evaluation Board Description
- Chapter 3—Capacitor Selection

FCC Warning

This equipment is intended for use in a laboratory test environment only. It generates, uses, and can radiate radio frequency energy and has not been tested for compliance with the limits of computing devices pursuant to subpart J of part 15 of FCC rules, which are designed to provide reasonable protection against radio frequency interference. Operation of this equipment in other environments may cause interference with radio communications, in which case the user at his own expense will be required to take whatever measures may be required to correct this interference.



Contents

1	Introduction	1-1
1.1	TPS6040x Evaluation Board	1-2
1.2	Basic Operation of the Devices	1-2
1.3	Family of Devices	1-2
2	Evaluation Board Description	2-1
2.1	Inverter With Filter and Post Regulator	2-2
2.2	Voltage Doubler/Inverter	2-5
2.3	Doubling Inverter	2-6
2.4	Step-Down Charge Pump	2-7
2.5	Layout of the EVM	2-8
2.6	Setup of the EVM	2-8
3	Capacitor Selection	3-1

Figures

2-1	Schematic for a Typical Application Circuit	2-3
2-2	Top Silk Screen and Top Layer	2-3
2-3	Schematic of the Voltage Doubler/Inverter	2-5
2-4	Top Silk Screen and Top Layer	2-5
2-5	Schematic of the Doubling Inverter	2-6
2-6	Top Silk Screen and Top Layer	2-6
2-7	Schematic of the Step-Down Configuration	2-7
2-8	Top Silk Screen and Top Layer	2-7
2-9	TPS60400 Evaluation Board	2-8

Tables

1-1	Device List	1-2
2-1	Bill of Materials for Inverter	2-4
2-2	Bill of Materials for Inverter With Filter and Post Regulator	2-4
2-3	Typical Capacitor Values	2-4
2-4	Bill of Materials for Doubler/Inverter	2-5
2-5	Bill of Materials for Doubling Inverter	2-6
2-6	Bill of Materials for Step-Down Charge Pump	2-7

Introduction

The evaluation board for the new Texas Instruments (TI) charge pump devices (TPS60400 to TPS60403) may help designers evaluate the performance of the devices.

Topic	Page
1.1 TPS6040x Evaluation Board	1-2
1.2 Basic Operation of the Devices	1-2
1.3 Family of Devices	1-2

1.1 TPS6040x Evaluation Board

The layout of charge pumps is critical. The suggested layout of the evaluation board can be used as a reference to reduce design time. The evaluation board is split into four sections, each section contains a different application circuit for the devices.

- Simple inverter or inverter with filter and post regulator (e.g. for LCD bias)
- Doubling inverter ($V_{OUT} = -2 V_{IN}$)
- Combined doubler/inverter ($V_{OUT1} = -V_{IN}$; $V_{OUT2} = 2 V_{IN}$)
- Step down charge pump ($V_{OUT} = 0.5 V_{IN}$)

1.2 Basic Operation of the Devices

The Texas Instruments TPS6040x charge pumps are unregulated voltage inverters intended for use with input voltages in the range of 1.8 V to 5 V. The output voltage is converted to be the inverse of the input voltage. Output current up to 60 mA can be drawn.

The TPS604x devices consist of a single inverter stage with its capacitors $C_{(FLY)}$ and C_O . For a functional description, refer to the data sheet (SLVS324).

1.3 Family of Devices

The devices of the TPS6040x family differ only in their operating frequency, and in their quiescent current. The TPS60400 changes its switching frequency with the current drawn, whereas the TPS60401 to TPS60403 operate at fixed frequencies.

Table 1–1. Device List

Device	Typical Operating Frequency	Typical Quiescent Current
TPS60400	50 kHz to 250 kHz (load dependent)	125 μ A
TPS60401	20 kHz	65 μ A
TPS60402	50 kHz	120 μ A
TPS60403	250 kHz	425 μ A

Evaluation Board Description

This chapter provides schematics and the layout of the EVM. It contains a bill of materials that shows the components used for the different applications of the EVM. The layout and the component placement of the top and bottom sides of the board are also shown.

Topic	Page
2.1 Inverter With Filter and Post Regulator	2-2
2.2 Voltage Doubler/Inverter	2-5
2.3 Doubling Inverter	2-6
2.4 Step-Down Charge Pump	2-7
2.5 Layout of the EVM	2-8
2.6 Setup of the EVM	2-8

2.1 Inverter With Filter and Post Regulator

Figure 2–1 shows the schematic of the application. A TPS6040x charge pump is used to generate a negative output voltage, which is filtered using R10 and C16. The output is stabilized by a TLV431 shunt regulator. Resistors R12 and R13 are used to adjust the output voltage.

The negative output voltage V_O is determined by the resistor network R13/R12 as follows:

$$V_O = - \left(1 + \frac{R13}{R12} \right) \times V_{ref} - R13 \times I_{I(ref)} \quad (1)$$

Where:

V_{ref} is typically 1.24 V.

$I_{I(ref)}$ is the reference input current, which is typically about 0.15 μ A.

The resistors R10 and R11 should provide a cathode current $|I_{(KA,min)}| \geq 0.08$ mA to the TLV431 at minimum V_I .

Refer to the TLV431 data sheet (literature number SLVS139) for further information.

Capacitors C10, C13, C14, C17 and C18 are not used in this application. They are used for providing different footprints for various capacitors.

The schematic in Figure 2–1 (b) shows the minimal configuration needed for an inverter.

Figure 2–1. Schematic for a Typical Application Circuit

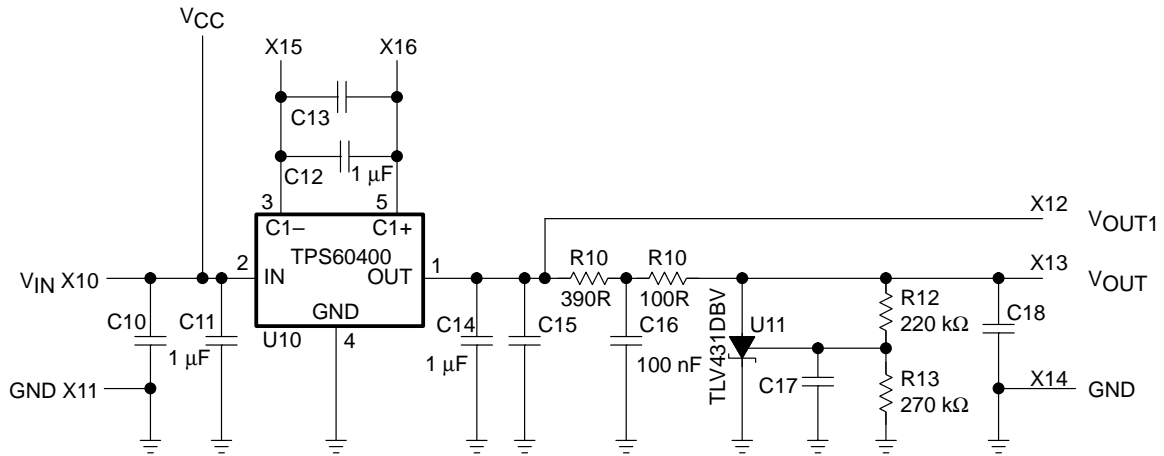

(a)

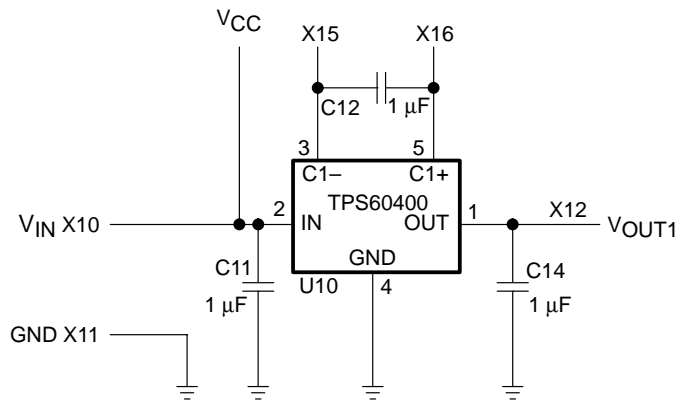

(b) Standard Inverter

Figure 2–2. Top Silk Screen and Top Layer

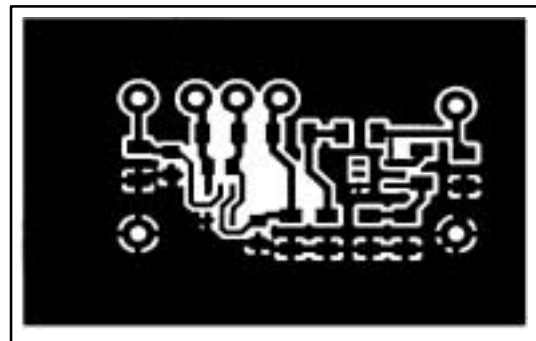
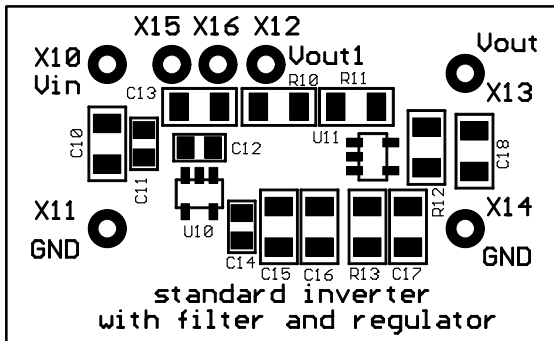

Table 2–1. Bill of Materials for Inverter

Reference	Part	Description
X10 to X16	MC S1–B	Connector
U10	TPS6040x	Charge pump
C11	0805	Input capacitor
C12	0805	Flying capacitor
C14	0805	Output capacitor

Table 2–2. Bill of Materials for Inverter With Filter and Post Regulator

Reference	Part	Description
X10 to X16	MC S1–B	Connector
U10	TPS6040x	Charge pump
U11	TLV431DBV	Shunt regulator
C10, C11	1206 or 0805	Input capacitor
C12, C13	1206 or 0805	Flying capacitor
C14, C15	1206 or 0805	Output capacitor
C16	1206	Capacitor for RC-filter
R10	1206	Resistor for RC-filter
R11	1206	Shunt resistor for post regulator
R12, R13	0805	Voltage selection resistors

Table 2–3. Typical Capacitor Values

Device	Input Capacitor	Flying Capacitor	Output Capacitor
TPS60400	1 μ F	1 μ F	1 μ F
TPS60401	10 μ F	10 μ F	10 μ F
TPS60402	3.3 μ F	3.3 μ F	3.3 μ F
TPS60403	1 μ F	1 μ F	1 μ F

2.2 Voltage Doubler/Inverter

Figure 2–3 shows the TPS6040x in a dual output application. The no load output voltage of V_{POS} is twice the input voltage. When loaded, the output voltage will decrease due to the forward voltage of D20 and D21. Schottky diodes can also be used. This will increase the output voltage under load. V_{NEG} is the inverting output with $V_{NEG} = -V_{IN}$.

Input current is about 2 times the output current at V_{POS} plus the output current at V_{NEG} .

Figure 2–3. Schematic of the Voltage Doubler/Inverter

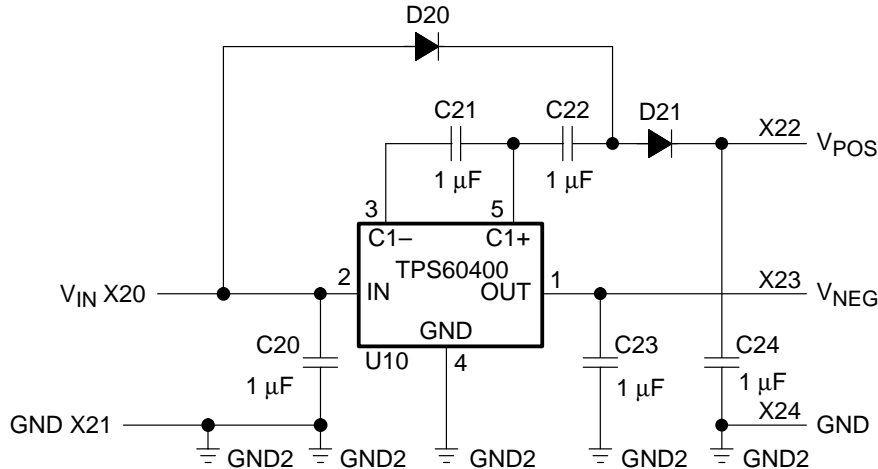

Figure 2–4. Top Silk Screen and Top Layer

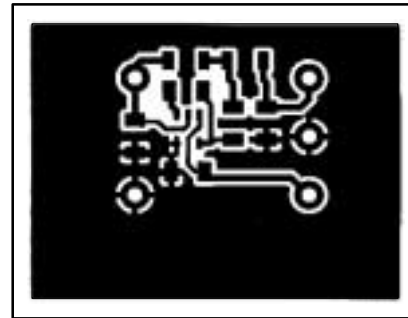
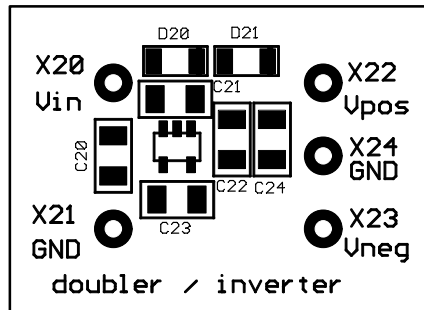

Table 2–4. Bill of Materials for Doubler/Inverter

Reference	Part	Description
X20 to X23	MC S1–B	Connector
U20	TPS6040x	Charge pump
C20	1206	Input capacitor
C21	1206	Flying capacitor
C22	1206	Capacitor for doubler stage
C23	1206	Output capacitor for inverting output
C24	1206	Output capacitor for 2 x V_{IN} output
D20, D21	Mini melf	Diode for doubler stage

2.3 Doubling Inverter

Two TPS6040x devices are connected in series to convert a input voltage in the range of 1.8 V to 5 V to an output voltage in the range of -3.6 V to -10 V. Capacitors C40, C41, C42, and C44 must have a voltage rating according to the input voltage, the output capacitor must have a voltage rating of at least twice the input voltage.

Figure 2–5. Schematic of the Doubling Inverter

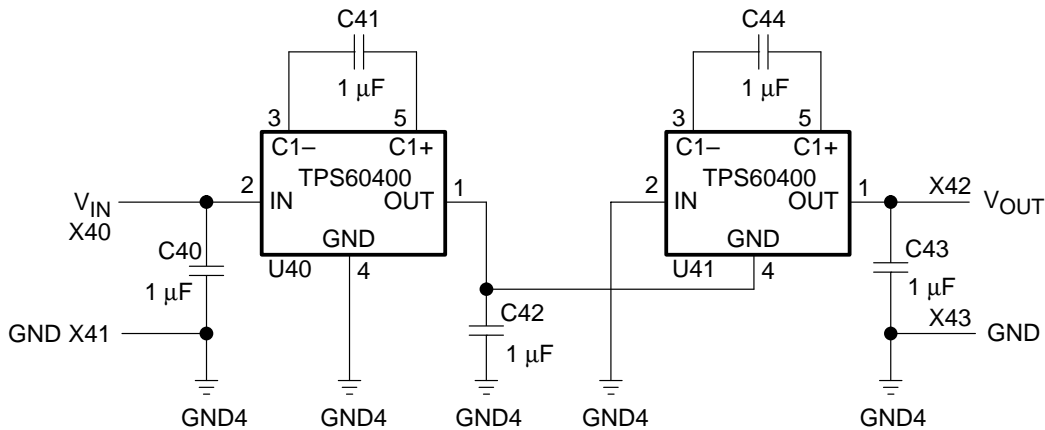

Figure 2–6. Top Silk Screen and Top Layer

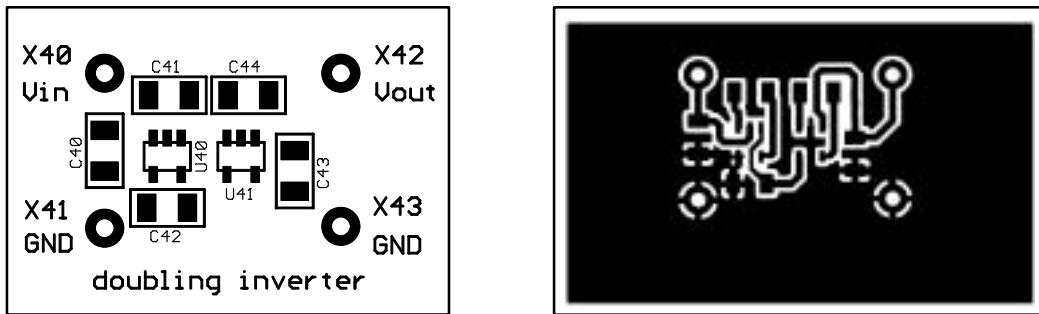

Table 2–5. Bill of Materials for Doubling Inverter

Reference	Part	Description
X40 to X43	MC S1–B	Connector
U40, U41	TPS6040x	Charge pump
C40	1206	Input capacitor
C41, C44	1206	Flying capacitor
C42	1206	Output capacitor for first inverter
C43	1206	Output capacitor, voltage rating: $2 V_{IN}$

2.4 Step-Down Charge Pump

This device can also be used to step down the input voltage by a factor of two. The output current is twice the input current. To operate an inverter in a step down configuration simply exchange the GND and the OUT pin of the inverter.

The output resistance is typically 15 Ω for a 5 V to 2.5 V conversion and it is about 8 Ω with an input voltage of 7 V.

The schematic shows the configuration. For further information, refer to the TPS6040x data sheet (literature number SLVS324).

Figure 2–7. Schematic of the Step-Down Configuration

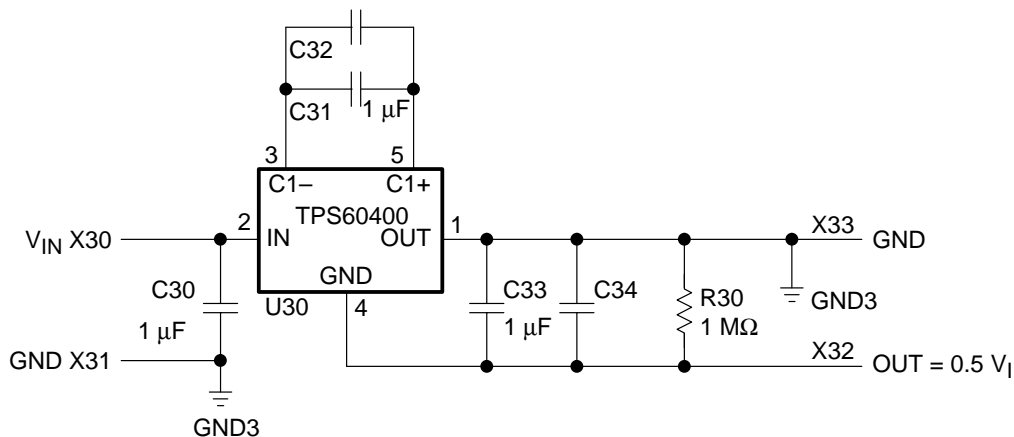

Figure 2–8. Top Silk Screen and Top Layer

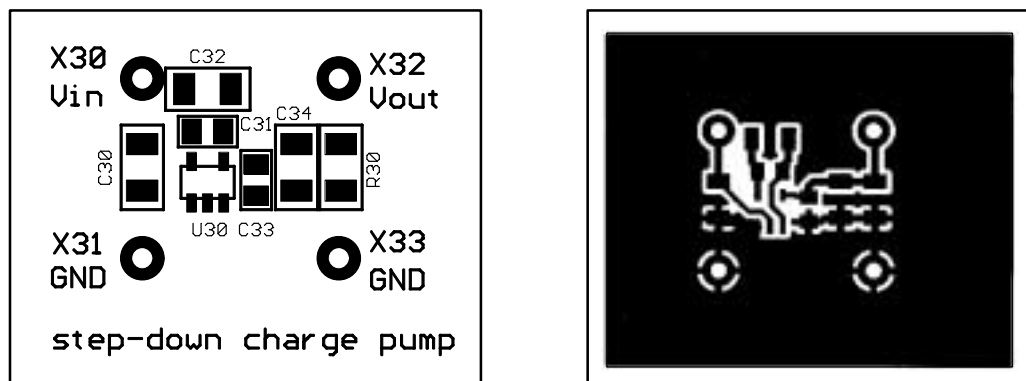

Table 2–6. Bill of Materials for Step-Down Charge Pump

Reference	Part	Description
X30 to X33	MC S1–B	Connector
U30	TPS6040x	Charge pump
C30	1206	Input capacitor
C31, C32	1206 or 0805	Flying capacitor
C33, C34	1206 or 0805	Output capacitor
R30	1206	Load resistor

2.5 Layout of the EVM

Figure 2–9 shows the entire evaluation board. All four sections of the board are separate. The bottom layer of the board consists of four independent GND planes to increase flexibility.

Figure 2–9. TPS60400 Evaluation Board

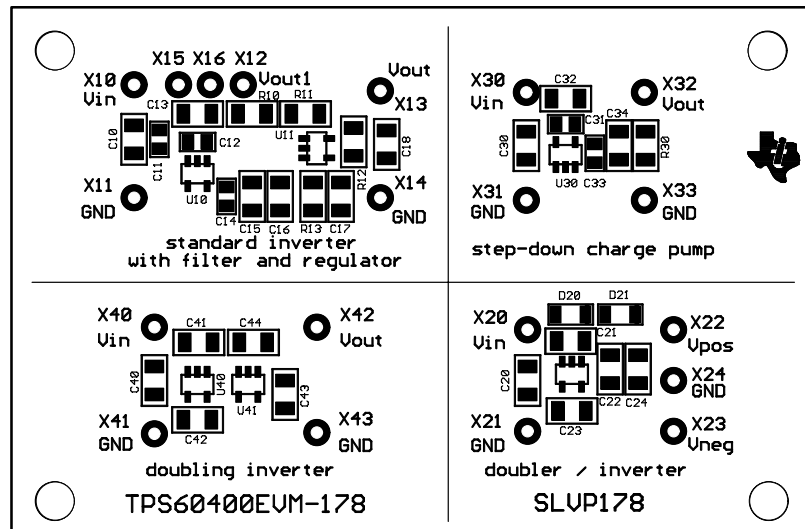

2.6 Setup of the EVM

For proper operation of the EVM, follow these few steps:

- 1) Assemble the components needed for the application to be tested. Sometimes pads in different size have been added to use either 1206 or 0805 sized components.
- 2) Connect a signal source (or a battery pack) with the appropriate voltage level between the input (V_{IN}) and ground (GND): 1.8 V to 5 V

Capacitor Selection

For the maximum output current and best performance, it is recommended that the flying and output capacitors have a minimum value which is listed in Table 2–3. For lower output currents or higher allowed output voltage ripple, smaller capacitors can also be used. With flying capacitors smaller than those listed in Table 2–3, the maximum output current will decrease. The best performance of the charge pumps can be seen with ceramic capacitors. To reduce the spikes during turnover from the transfer phase (charging of the flying capacitor) to that of transferring the current to the output capacitor, a ceramic capacitor is recommended at the input and output. Tantalum capacitors are not able to filter these spikes because their equivalent series resistance (ESR) is too high. When using tantalum capacitors as input or output capacitors, connect a ceramic capacitor in parallel to reduce voltage spikes.

